

Caution | Please Read the Manual Before Use.
Real Color of Product and Catalog Image Color Can Be Different.
Contents in This Catalog Can Be Changed Without Any Notice.



SMART DEVICE



SMART DEVICE

Product Catalog

MX On Corporation

HEAD ADDRESS: 11-35, Simin-daero 327beon-gil, Dongan-gu, Anyang-si, Gyeonggi-do 14055, Republic of Korea
OFFICE TEL: 82-31-465-3366
FAX: 82-31-465-3355

V 1.0E 251225

mxon.co.kr/eng

MX On Corporation Is an AX·DX-Based Smart Factory Total Solution Platform Company with Technical Expertise Extending from HMI/SCADA Development and Manufacturing to Robot Control and Logistics Automation.

SMART DEVICE

CONTENTS

SMART DEVICE Product Line-up Overview	04P	MIO LoRa SERIES Industrial Wireless Communication Devices	22P
MSR SERIES Industrial Barcode Scanner	06P	MGW SERIES IoT Gateway	28P
MWD SERIES Barcode Scanner Dongle	10P	Global Business Network & Services Sales	32P
MIO Remote I/O SERIES Industrial Remote I/O	14P		

SMART DEVICE LINE-UP



High-Reliability Industrial Barcode Scanner Combining Safety and Ease of Use

Ex / Non-Ex Barcode Scanner



Dongle for Easy Connectivity with Devices Without IrDA or Bluetooth

(Exclusive for Barcode Scanners) Explosion-Proof and Non-Explosion-Proof Wireless Communication Dongle



MIO REMOTE I/O

Remote I/O Device with a Compact Form Factor, Enhancing System Flexibility and Efficiency

Industrial Remote I/O Device



MIO LoRa

Secure Device Offering Diverse I/O with Long-Range Wireless Communication up to 2 km Based on LoRa

Industrial Wireless Communication Device



Data Integration and Conversion Device Supporting Over 400 Industrial Communication Protocols

IoT Gateway Connecting Industrial Equipment

MSR SERIES

Ex / Non-Ex Barcode Scanner

Ex     (On Progress)

Non-Ex  



Explosion-Proof Wireless Barcode Scanner
(Supports IrDA and Bluetooth)

Standard Wired / Wireless Barcode Scanner
(Supports IrDA and USB)



FEATURES

Explosion-Proof Wireless Barcode Scanner | MSR-B2MWA-Ex

Intrinsically Safe Explosion-Proof Structure

UL/cUL: Class 1, Division 2 Groups A, B, C, D, T6
IECEX, ATEX, KCs: Ex ic ec IIC T6 (In Progress)

Field-Preferred Gun-Type Design

Shock-Resistant Urethane Exterior
IP66-Rated Waterproof and Dustproof Performance
Compact Design with Excellent Grip

Supports IrDA / Bluetooth Wireless Communication

Supports Multi SEND with Our HMI IrDA Compatible
IrDA Communication with Third-Party HMI, PC via
MWD Dongle
Bluetooth Pairing Supported with Our HMI, PC and
MWD Dongle

Secure Management of Barcode Data

Can Temporarily Store up to 20 Recent Barcodes
Transmission Status Confirmed via LED Indicator

Standard Wired / Wireless Barcode Scanner | MSR-B2MWB

Compact Design Combining Durability and Portability

Shock-Resistant Urethane Exterior
IP67-Rated Waterproof and Dustproof Performance
Compact Design with Excellent Grip

Supports Wired and Wireless USB Communication

Easy 2.4GHz RF Wireless Communication Using a
USB Dongle
Stable Wired Communication via USB Cable

Wide IrDA Infrared Communication Compatibility

Full Support for Proprietary HMI and Multi SEND
Functionality
Compatible Communication with Various Devices
Such as Third-Party HMI and PCs via MWD Dongle

Secure Barcode Data Management

Built-In Memory Capable of Storing up to 25,000
Barcodes
Select and Transmit Only the Required Data Using
UP/DOWN Buttons

MSR SPECIFICATIONS

Functional	MSR-B2MWA-Ex	MSR-B2MWB	MSR-B2MWA-DONGLE
Display	Display Type	LED	1.3" OLED
	Color	-	Gray
	Display Area(mm)	-	31.42 x 16.7
	Resolution(dot)	-	128 x 64
	Display Life	-	50,000 Hours
Indicators	Bluetooth, Status, Battery Gauge		-
	Type	640 x 400 1D/2D CMOS Barcode	1280 x 960, 1D/2D Barcode
Barcode	Code 39, Code 128, PDF417, UPC, Data Matrix, QR Code		-
	USB	USB Type C, Charge Only	USB Type C, V1.1 Compatible 1 Channel
Interface	Compliant to IrDA Physical Layer Standard Up to 115.2 kbit/s(SIR), More than 0.5M in Open Space Connection with MX On HMI Equipment		Compliant to IrDA Physical Layer Standard Up to 115.2 kbit/s(SIR), Range Up to 1.0M in Open Space Connection with MX On HMI Equipment
	2.4GHz RF	2402MHz to 2480MHz, Bluetooth 5.2 LE, Range Up to 5M in Open Space	2322MHz to 2527MHz, IEEE 802.15.4, Range Up to 15M in Open Space
	Function Key	Unlock Type Push Switch 4EA (Power/Bluetooth/Send/Scan)	Unlock Type Push Switch 6EA (Power/Scan/Send/Erase/Up/Down)
	Memory	Storage Memory	-
	Battery	Rechargeable Battery	Single Li-ion 3.6Vdc, 2500mAh Operating Time: 6+ Hours (18000+,1Second interval) Charging Time: 5 Hours(Non-Operating) Standby On: 29+ Hours
Power	Consumption	3W	3W
Other	Status LED	-	2 LEDs(Power, Charge) Built in
	Operation Temperature(°C)	-10 ~ +50	+10 ~ +45
	Storage Temperature(°C)	-	-20 ~ +60
	Protection Classification	IP54	Product Body IP67
	Operation Humidity(%RH)	-	0 ~ 90(No Dew)
	Atmosphere	-	No Corrosive Gas
	Vibration Endurance	Amplitude: 10≤F < 25Hz(2G) X, Y, Z each Direction(for 30 Minutes)	
	Static Electricity Discharge	Connective Discharge from EN61000-4-2: ±4kV	
	Shock Endurance	10G X, Y, Z each Direction(for 3 Times)	
	Certification	KC, CE, UL/cUL in Hazloc KCs, IECEx, ATEX(On Progress)	KC, CE
Structure	External Dimension(mm)	188.9 x 100.1 x 60.3	143.5 x 54 x 36
	Weight(kg)	0.416	0.18
	Case Material	PC, Urethane	PC

DRAWING

MSR-B2MWA-Ex

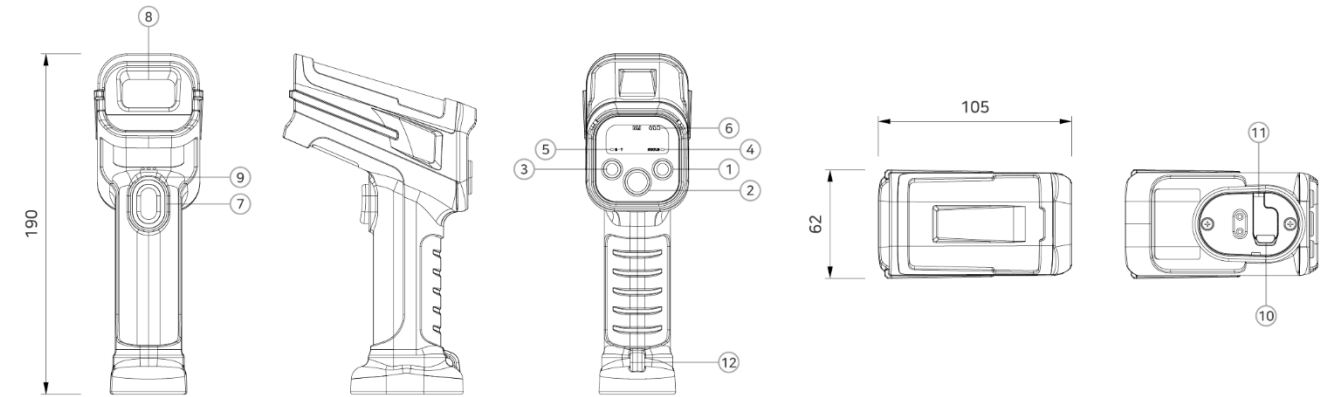

- ① Power Switch
- ② Send Switch
- ③ Bluetooth Switch
- ④ Status LED
- ⑤ Bluetooth Status LED
- ⑥ Battery Level
- ⑦ Scan Switch
- ⑧ Scanner Window and IrDA Transmit / Receive
- ⑨ Buzzer Hall
- ⑩ Bottom Cover
- ⑪ USB-C Port for Charging
- ⑫ Strap Holding Hole

MSR-B2MWB
MSR-B2MWA-DONGLE

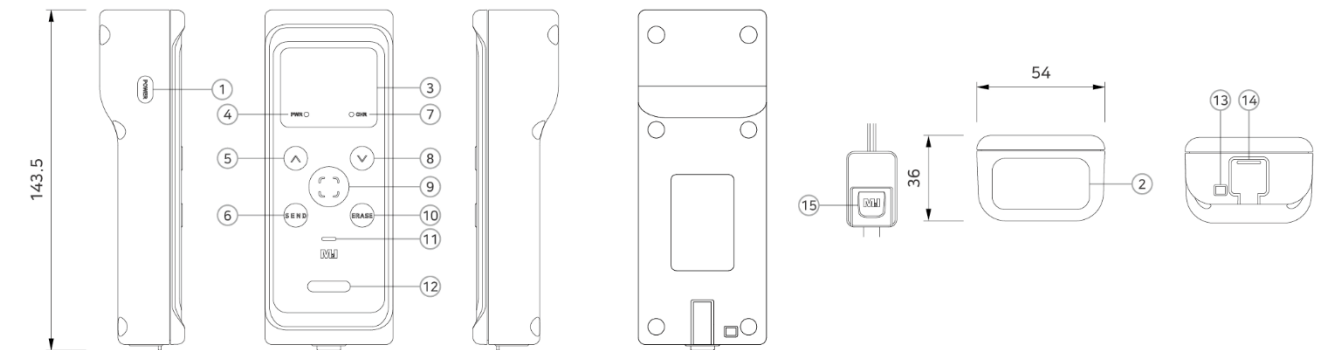

- ① Power Switch
- ② Scanner Window and IrDA Transmit / Receive
- ③ OLED
- ④ Power Indicator
- ⑤ Up Switch
- ⑥ Send Switch
- ⑦ Charging Indicator
- ⑧ Down Switch
- ⑨ Scan Switch
- ⑩ Erase Switch
- ⑪ Buzzer Hall
- ⑫ Status LED
- ⑬ Strap Holding Hole
- ⑭ Rear Case
- ⑮ USB Dongle (Included in Strap)

MWD SERIES

EX / Non-Ex Wireless Communication Dongle

Ex    (On Progress)

Non-Ex    (On Progress)



FEATURES

Provides Wide Compatibility in USB HID Mode

Fully Compatible with Proprietary HMI as Well as Third-Party HMI, PCs, and Other Devices Through USB HID Operation

Seamless Data Transmission in USB Serial Mode

Ensures Data Reliability via Proprietary HMI Protocol When Using USB Serial Mode

Supports Long-Range Bluetooth Communication

- MWD-BTE100(-Ex): Up to Approximately 8 m Transmission
- MWD-BTR100(-Ex): Up to Approximately 5 m Transmission

More Convenient with QR Code / IrDA

Provides an Easy QR Interface in Environments with Multiple Barcode Readers
Instantly Transmits Data via IrDA Sensor Without the Pairing Process

MWD CONNECTION METHODS

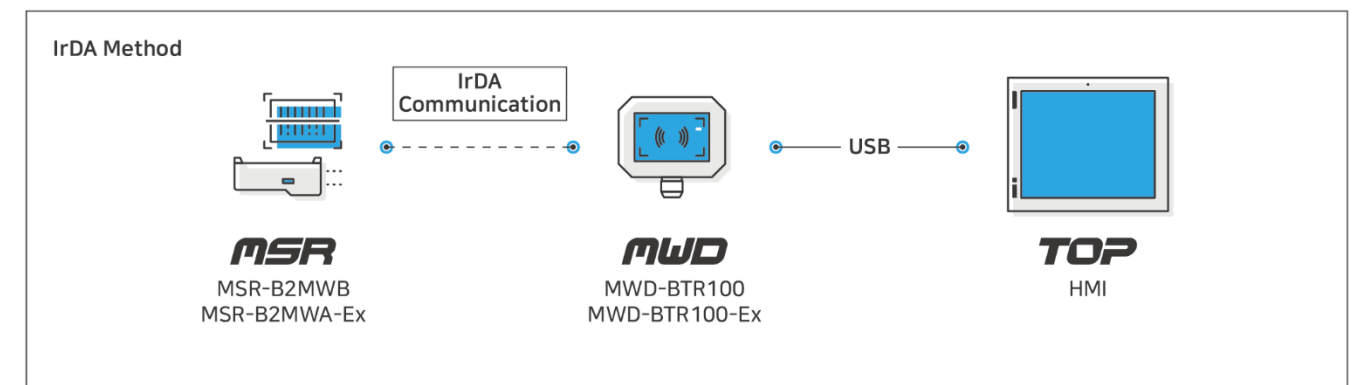
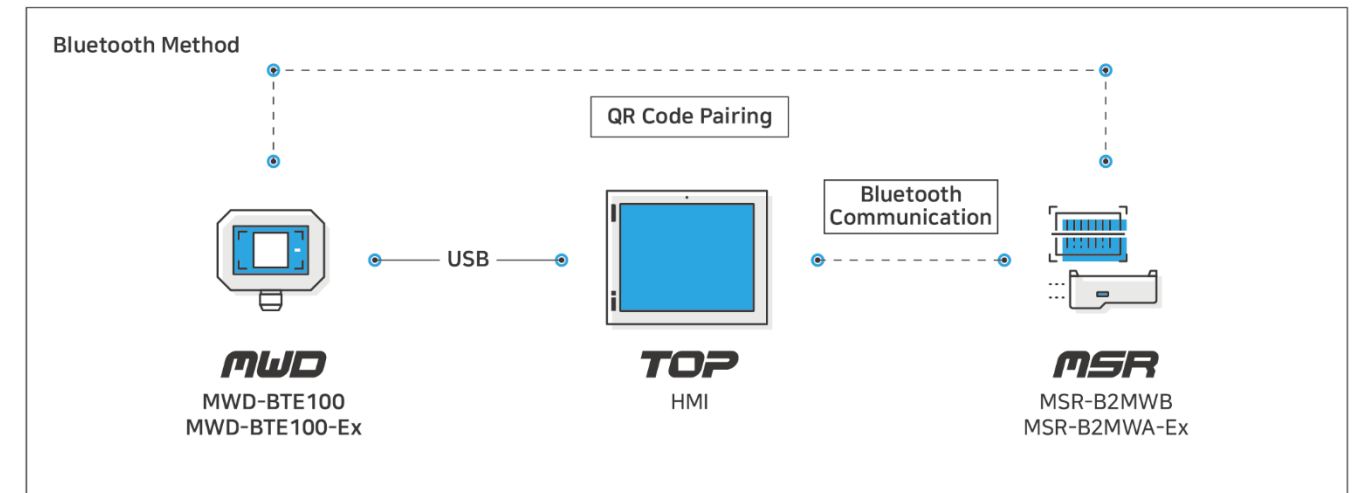

* For Detailed Usage Instructions, Please Refer to the Hardware Manual.

MWD SPECIFICATIONS

	Non-Ex Model Ex Model	MWD-BTE100 MWD-BTE100-Ex	MWD-BTR100 MWD-BTR100-Ex
Display	E-Paper	1.54" Pairing QR	-
Status LED	RED	Power ON & Pairing Wait	HID Interface
	GREEN	Pairing OK	Serial Interface
Frequency		2400 ~ 2483.5Mhz	2402 ~ 2480Mhz
Spec.		Bluetooth® 5.1 Low Energy(BLE)	Bluetooth® 5.0 Low Energy(BLE)
Data Rate		1Mbps@Typ	
Wireless Bluetooth	Max Output	+8.5dBm@Typ	+0.55dBm(Including Antenna gain)
	RF Sensitivity	-96dBm@Typ	-
Operating Range		Up to 8 meters(communication in flat terrain)	Up to 5M in open space
Security(*AP Setting)		AES-128bit and AES-256bit encryption	WEP(64/128), WPA-PSK+(TKIP, AES), WPA2-PSK+(TKIP, AES) *AES Recommend
IrDA	IrDA	-	Compliant to IrDA physical layer standard up to 115.2 kbit /s(SIR), 0.7M@ Open space communication, MX On HMI dedicated communication
Power	USB	USB Type-A, for data communication and power supply, 1-meter cable length	
Environment	Operation Temperature(°C)	-20 ~ +50	
	Storage Temperature(°C)	-20 ~ +60	
	Operation Humidity(%RH)	0 ~ 90(No dew)	
	Atmosphere	No corrosive gas	
	Vibration Endurance	Amplitude: 10sF < 25Hz(2G) X,Y,Z each direction(for 30 minutes)	
	Static Electricity Discharge	Connective discharge from EN61000-4-2: ±4kV	
	Shock Endurance	10G X,Y,Z each direction(for 3 times)	
Protection Classification	IP54		
Certification(On Progress)	General Model: KC, CE, UL/cUL Explosion Proof Model: KC, CE, KCs		
Structure	External Dimension(mm)	82.2 × 40 × 62.2	
	Weight(kg)	0.1	
	Cooling System	Natural air circulation	
	Case Material	Plastic	

DRAWING

MWD-BTE100
MWD-BTE100-Ex

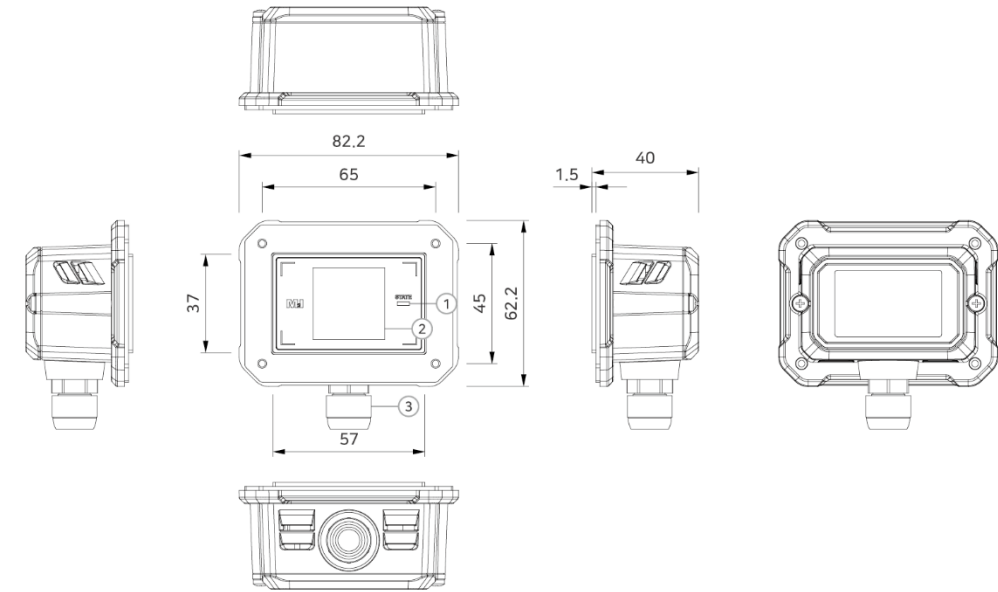

① Status LED ② E-Paper ③ USB 2.0

MWD-BTR100
MWD-BTR100-Ex

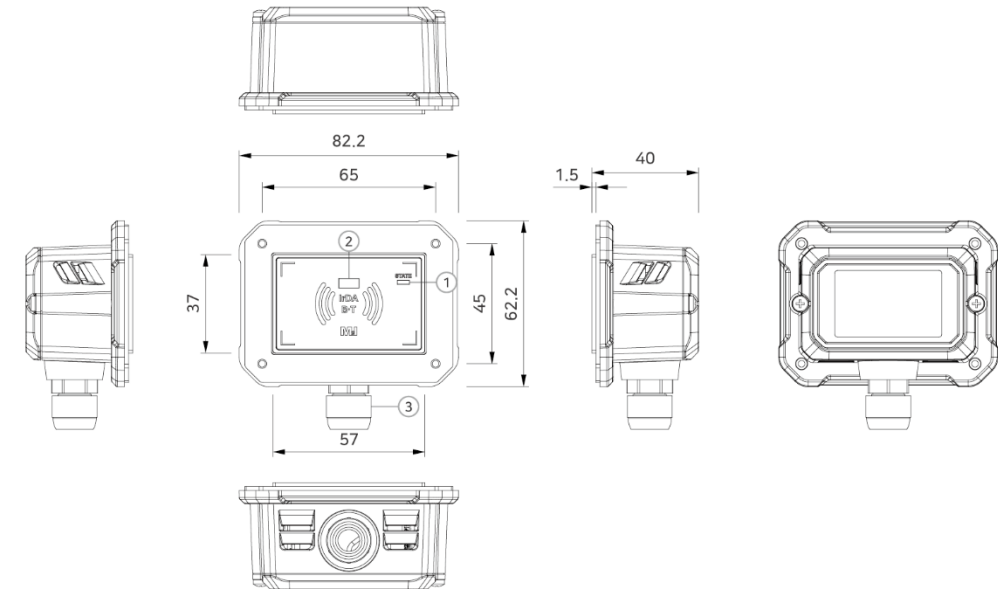

① Status LED ② IrDA Sensor ③ USB 2.0

MIO Remote I/O SERIES

Industrial Remote I/O Device



MIO REMOTE I/O

FEATURES

Communication

Supports Industrial Network Protocols Such as Modbus TCP, Modbus RTU, and EtherCAT

Compact

Ultra-Compact Size Maximizes Installation Space Efficiency and Simplifies Wiring

Hot Swap

Minimize Downtime and Improve Maintenance Efficiency by Replacing Modules During Operation Without Powering Off

Durability

Robust Design Built to Operate in Various Industrial Environments Including Noise, Vibration, and Temperature Fluctuations

Module

Flexible Configuration with Various I/O and Expansion Modules, Optimized for Field Conditions (Up to 32 Slots)

MIO Master

Provides Dedicated, Easy-to-Use Software (MIO Master) Intuitive UI Enables Fast Initial Setup and Real-Time Control/Monitoring

Remote I/O CONNECTION METHODS

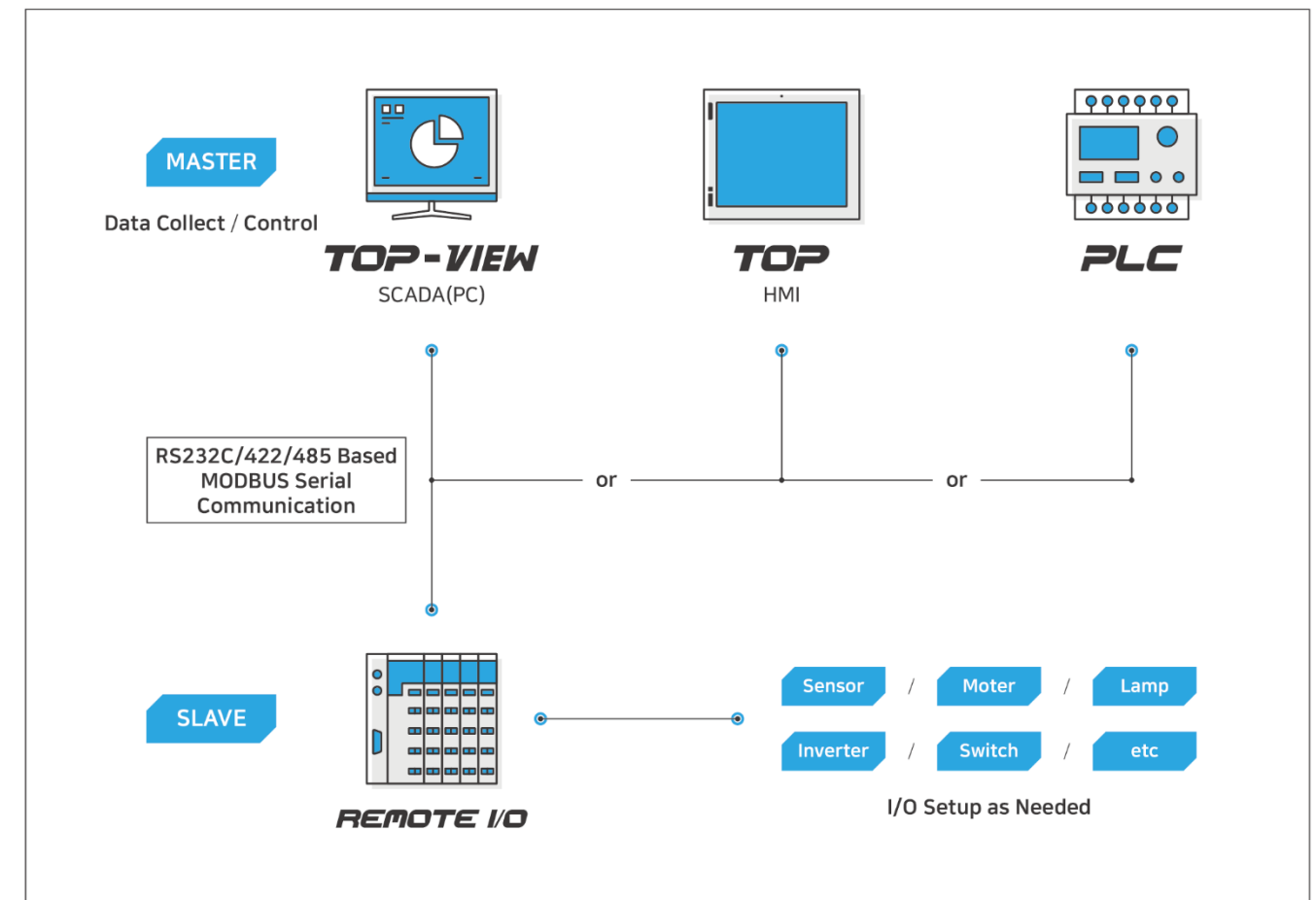

MIO-CMROA SPECIFICATIONS

COUPLER MODULE

Functional		MIO-CMROA	MIO-CMTOA	MIO-CECOA	MIO-END-01	
Type	Protocol	Modbus RTU/ASCII	Modbus TCP	EtherCAT	-	
Power	Input Voltage	24Vdc(19.2 ~ 28.8Vdc)			-	
	Power Dissipation	50mA Typical@24Vdc			-	
	Voltage Sag	24Vdc, Within 10ms			-	
	Insulation Resistance	500Vdc, 10MΩ			-	
	Current for I/O Module	1.4A@5Vdc			-	
	Isolation	System Power to Internal Logic: Isolation System Power I/O Driver: Isolation			-	
	Field Power	Supply Voltage: 24Vdc Typ. Supply Voltage Range: 11 ~ 28.8Vdc			-	
Max. Current Field Power Contact	Max. 7A@24Vdc			-		
Interface Connector	Connector: DSUB 9Pin x 1	Connector: RJ-45 x 2			-	
Physical Interface	RS-232C, 485/422 Asynchronous Data Bit: 7/8 Bits, Stop Bit: 1/2 Bits, Parity Bit: None/Odd/Even Baud Rate: 2400 ~ 187.5kbps	IEEE802.3i/IEEE802.3u, 10BASE-T/100BASE-TX 2-Port Ethernet Switch	IEEE802.3u, 100BASE-TX	-		
Interface	Max. Length Bus Line	500m@RS-485/422, 10m@RS-232C	Up to 100m		-	
	Max. Expansion Module	32 Slots			-	
	Max. Nodes	255 Nodes@RS-485/422	Limited by Ethernet Specification	65,535	-	
	Node Setting	1 ~ 255		1 ~ 65,535	-	
	Baud Rate	Max. 187.5kbps	10/100Mbps	100Mbps	-	
	USB	Connector: USB Mini - B x 1			-	
	Memory	Max. Input Size	Input + Output Max. 256 Byte			-
		Max. Output Size	Input + Output Max. 256 Byte			-
	Other	Indicator	7 LED Modbus Status, I/O Module Status, Coupler Status, System Power Status, RX/TX Status, Field Power Status	7 LED EtherCAT Status, EtherCAT RUN/ERR Status, I/O Module Status, Coupler Status, System Power Status, Field Power Status	-	
		Wiring	AWG 26 to 20			-
Environment	Operation Temperature(°C)	-10 ~ +50				
	Storage Temperature(°C)	-20 ~ +60				
	Operation Humidity(%RH)	0 ~ 90(No Dew)				
	Atmosphere	No Corrosive Gas				
	Vibration Endurance	Amplitude: 10sF < 25Hz(2G) X, Y, Z each Direction(for 30 Minutes)				
	Noise Immunity	1000Vp-p(Pulse Width 1μs)				
	Static Electricity Discharge	Connective Discharge from EN61000-4-2: ±4kV				
	Shock Endurance	10G X, Y, Z each Direction(for 3 Times)				
	Ground Connection	Class 3(100Ω Under)				
	Protection Classification	IP20				
	Certification	KC, CE, UL/cUL				
	External Dimension(mm)	52.2 x 101 x 75				
	Structure	Weight(kg)	0.16			
Cooling System		Natural Air Circulation				
Case Material		PC(Resistance to Flame)				

MIO-DI, DO SPECIFICATIONS

I/O MODULE

Functional		MIO-DIN08-01	MIO-DIP08-01	MIO-DON08-01	MIO-DOP08-01	MIO-DOR04-01
Type	Input/Output Type	8 Channels Sink Type, Input	8 Channels Source Type, Input	8 Channels Sink Type, Output	8 Channels Source Type, Output	4 Channels Relay Type, Output
Power	Input/Output Voltage	24Vdc Typ. On-State Min. 10.2Vdc ~ Max. 28.8Vdc, Off-State Max. 5Vdc		24Vdc Typ. Min. 11.0Vdc ~ Max. 28.8Vdc, On-State Voltage Drop: Max. 0.3Vdc@25°C Off-State Leakage Current: Max. 50uA		A Contact, 24Vdc
	Power Dissipation	Max. 70mA@5.0Vdc		Max. 90mA@5.0Vdc		Max. 200mA@5.0Vdc
	Input/Output Current in On State	Max. 6mA/ Channel@28.8Vdc		Max. 0.5A/ Channel@28.8Vdc		2A/Channel@24Vdc
	Max. On-State Voltage Drop	-		Max. 0.3Vdc@25°C		0.5V@2.0A, Resistive Load, 24Vdc
	Off-State Leakage Current	-		Max. 50uA		Max. 1.5mA
	Typ. Input Impedance	Typ. 4.7KΩ		-		-
	Input/Output Signal Delay	Off to On: Max. 0.1ms On to Off: Max. 0.5ms		Off to On: Max. 0.3ms On to Off: Max. 0.5ms		Off to On: Max. 3ms On to Off: Max. 3ms
Input Filter(Digital)	0.5ms		-		-	
Isolation	Photocoupler					Relay Coil/ Contact Isolation
Common Type	2COM(Single Common), 24Vdc	2COM(Single Common), 0Vdc	2COM(Single Common), 24Vdc	2COM(Single Common), 0Vdc	4COM(1COM/1Channel)	
Field Power	Supply Voltage: 24Vdc Typ. Supply Voltage Range: 11 ~ 28.8Vdc					
Wiring	AWG 26 to 20					
Pin No.	Removable Terminal Block 10P					
Indicator	9 LED 8 Channel States, 1 Operating State				5 LED 4 Channel States, 1 Operating State	
Environment	Operation Temperature(°C)	-10 ~ +50				
	Storage Temperature(°C)	-20 ~ +60				
	Operation Humidity(%RH)	0 ~ 90(No dew)				
	Atmosphere	No Corrosive Gas				
	Vibration Endurance	Amplitude: 10sF < 25Hz(2G) X, Y, Z each Direction(for 30 Minutes)				
	Noise Immunity	1000Vp-p(Pulse Width 1μs)				
	Static Electricity Discharge	Connective Discharge from EN61000-4-2: ±4kV				
	Shock Endurance	10G X, Y, Z each Direction(for 3 Times)				
	Ground Connection	Class 3(100Ω Under)				
	Protection Classification	IP20				
Certification	KC, CE, UL/cUL					
Structure	External Dimension(mm)	12 x 101 x 75				
	Weight(kg)	0.06				
	Cooling System	Natural Air Circulation				
Case Material	PC(Resistance to Flame)					

MIO-DI, DO SPECIFICATIONS

I/O MODULE

Functional		MIO-DIN16-01	MIO-DIP16-01	MIO-DON16-01	MIO-DOP16-01
Type	Input/Output Type	16 Channels Sink Type, Input	16 Channels Source Type, Input	16 Channels Sink Type, Output	16 Channels Source Type, Output
Power	Input/Output Voltage	24Vdc Typ. On-State Min. 10.2Vdc ~ Max. 28.8Vdc, Off-State Max. 5Vdc		24Vdc Typ. Min. 11.0Vdc ~ Max. 28.8Vdc, On-State Voltage Drop: Max. 0.3Vdc@25°C Off-State Leakage Current: Max. 50uA	
	Power Dissipation	Max. 70mA@5.0Vdc		Max. 120mA@5.0Vdc	
	Input/Output Current in On State	Max. 6mA/ Channel@28.8Vdc		Max. 0.5A/ Channel@28.8Vdc	
	Max. On-State Voltage Drop	-		Max. 0.3Vdc@25°C	
Interface	Off-State Leakage Current	-		Max. 50uA	
	Typ. Input Impedance	Typ. 4.7KΩ		-	
	Input/Output Signal Delay	Off to On: Max. 0.1ms On to Off: Max. 0.5ms		Off to On: Max. 0.3ms On to Off: Max. 0.5ms	
	Input Filter(Digital)	0.5ms		-	
	Isolation	Photocoupler			
	Common Type	Not Support			
	Field Power	Supply Voltage: 24Vdc Typ. Supply Voltage Range: 11 ~ 28.8Vdc			
	Wiring	AWG 26 to 20			
	Pin No.	Removable Terminal Block 16P			
	Indicator	17 LED 16 Channel States, 1 Operating State			
Environment	Operation Temperature(°C)	-10 ~ +50			
	Storage Temperature(°C)	-20 ~ +60			
	Operation Humidity(%RH)	0 ~ 90(No dew)			
	Atmosphere	No Corrosive Gas			
	Vibration Endurance	Amplitude: 10≤F < 25Hz(2G) X, Y, Z each Direction(for 30 Minutes)			
	Noise Immunity	1000Vp-p(Pulse Width 1μs)			
	Static Electricity Discharge	Connective Discharge from EN61000-4-2: ±4kV			
	Shock Endurance	10G X, Y, Z each Direction(for 3 Times)			
	Ground Connection	Class 3(100Ω Under)			
	Protection Classification	IP20			
Structure	Certification	KC, CE, UL/cUL			
	External Dimension(mm)	12 x 101 x 75			
	Weight(kg)	0.06			
	Cooling System	Natural Air Circulation			
	Case Material	PC(Resistance to Flame)			

MIO-AI, AO SPECIFICATIONS

I/O MODULE

Functional		MIO-AIR02-01	MIO-AIV04-01	MIO-AIC04-01	MIO-AOV04-01	MIO-AOC04-01
Type	Input/Output Type	2 Channels Analog RTD Type	4 Channels Analog Voltage Type	4 Channels Analog Current Type	4 Channels Analog Voltage Type	4 Channels Analog Current Type
Power	Sensor Type and Input/Output Range	PT100 * -200.0 to +850.0°C	0 ~ 5 Vdc	0 ~ 20mA	0 ~ 5 Vdc	0 ~ 20mA
	Power Dissipation	Max. 70mA@5.0Vdc	Max. 200mA@5.0Vdc			
	Field Power	Max. 60mA@24Vdc				
	Typ. Input Impedance	-	Min. 500KΩ	Max. 250Ω	-	
Characteristic	Load	-	-	-	Min. 1KΩ	Max. 500Ω
	Data Format	16bits Integer				
	Resolution	0.0312°C/1bit	16bits, 0.076mV/1bit	16bits, 0.3uA/bit	16bits, 0.076mV/1bit	16bits, 0.3uA/bit
	Conversion Time	Approx. 70ms, All Channel@50Hz	4ms/All Channel			
	Module Error	±0.1% Full Scale@+25°C, ±0.3% Full Scale@-10°C, +50°C				
	Isolation	I/O to Logic: Capacitive Isolation, External Power : Transformer Isolation				
	Common Type	2COM (1Common/1Channel)	4COM (Single Common)			
	Wiring	AWG 26 to 20				
	Pin No.	Removable Terminal Block 10P				
	Indicator	3 LED 2 Channel States, 1 Operating State	5 LED 4 Channel States, 1 Operating State			
Environment	Operation Temperature(°C)	-10 ~ +50				
	Storage Temperature(°C)	-20 ~ +60				
	Operation Humidity(%RH)	0 ~ 90(No dew)				
	Atmosphere	No Corrosive Gas				
	Vibration Endurance	Amplitude: 10≤F < 25Hz(2G) X, Y, Z each Direction(for 30 Minutes)				
	Noise Immunity	1000Vp-p(Pulse Width 1μs)				
	Static Electricity Discharge	Connective Discharge from EN61000-4-2: ±4kV				
	Shock Endurance	10G X, Y, Z each Direction(for 3 Times)				
	Ground Connection	Class 3(100Ω Under)				
	Protection Classification	IP20				
Structure	Certification	KC, CE, UL/cUL				
	External Dimension(mm)	12 x 101 x 75				
	Weight(kg)	0.06				
	Cooling System	Natural Air Circulation				
	Case Material	PC(Resistance to Flame)				

MIO-PWR, COM SPECIFICATIONS

EXPANSION MODULE

Functional	MIO-PWROA	MIO-PWR0B	MIO-COM0A	MIO-COM0B	MIO-COM0C
Power	Input System Voltage: 24Vdc Typ.(20V ~ 28V) Voltage Sag: 24Vdc, Within 10ms Insulation Resistance: 500Vdc, 10MΩ Current for I/O Module: 1.4A@5Vdc Isolation: System Power to Internal Logic: Isolation System Power I/O Driver: Isolation				
Characteristic	Field Power: Supply Voltage: 24Vdc Typ. Supply Voltage Range: 11 ~ 28.8Vdc Max. Current Field Power Contact: Max. 7A@24Vdc Common Type: Not Support 16COM(Single Common) 24Vdc 16COM(Single Common) 0Vdc 8COM(Single Common) 24Vdc, 0Vdc Wiring: AWG 26 to 20 Other: Pin No. Removable Terminal Block 10P Removable Terminal Block 16P				
Indicator	3 LED: System Power Status, Module Status, Field Power Status 2 LED: Module Status, Field Power Status 1 LED: Module Status				
Environment	Operation Temperature(°C): -10 ~ +50 Storage Temperature(°C): -20 ~ +60 Operation Humidity(%RH): 0 ~ 90(No dew) Atmosphere: No Corrosive Gas Vibration Endurance: Amplitude: 10sF < 25Hz(2G) X, Y, Z each Direction(for 30 Minutes) Noise Immunity: 1000Vp-p(Pulse Width 1μs) Static Electricity Discharge: Connective Discharge from EN61000-4-2: ±4kV Shock Endurance: 10G X, Y, Z each Direction(for 3 Times) Ground Connection: Class 3(100Ω Under) Protection Classification: IP20 Certification: KC, CE, UL/cUL				
Structure	External Dimension(mm): 12 x 101 x 75 Weight(kg): 0.06 Cooling System: Natural Air Circulation Case Material: PC(Resistance to Flame)				

DRAWING

COUPLER MODULE

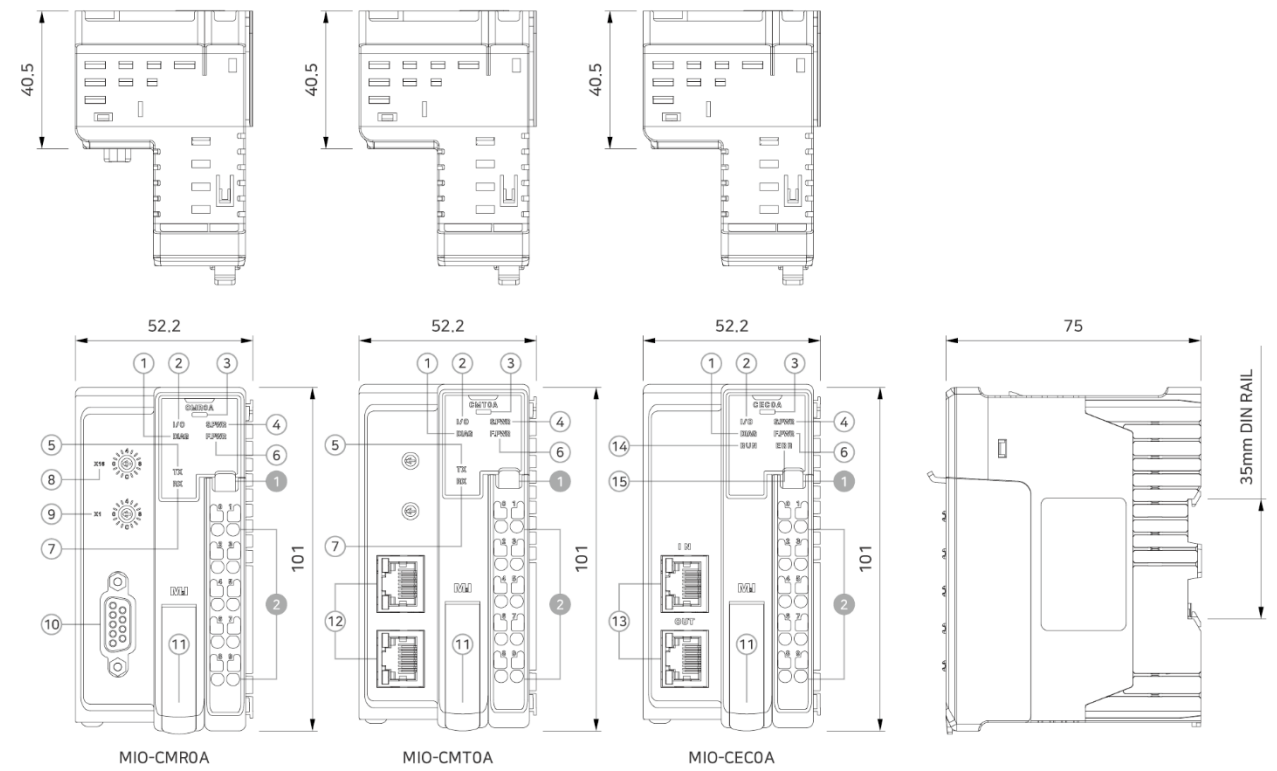

- ① Diagnostic LED
- ⑥ Field Power Status LED
- ⑪ USB Connector Cover
- ① Detachment Hook
- ② Extension I/O Module Status LED
- ⑦ RX Status LED
- ⑫ Ethernet
- ② Channel Terminal
- ③ Remote I/O Coupler Status LED
- ⑧ Node Number Setting Switch 16x
- ⑬ EthernetCAT I/O
- ④ System Power LED
- ⑨ Node Number Setting Switch 1x
- ⑭ Run Status LED
- ⑤ TX Status LED
- ⑩ MODBUS Communication Port
- ⑮ Error Status LED

I/O MODULE

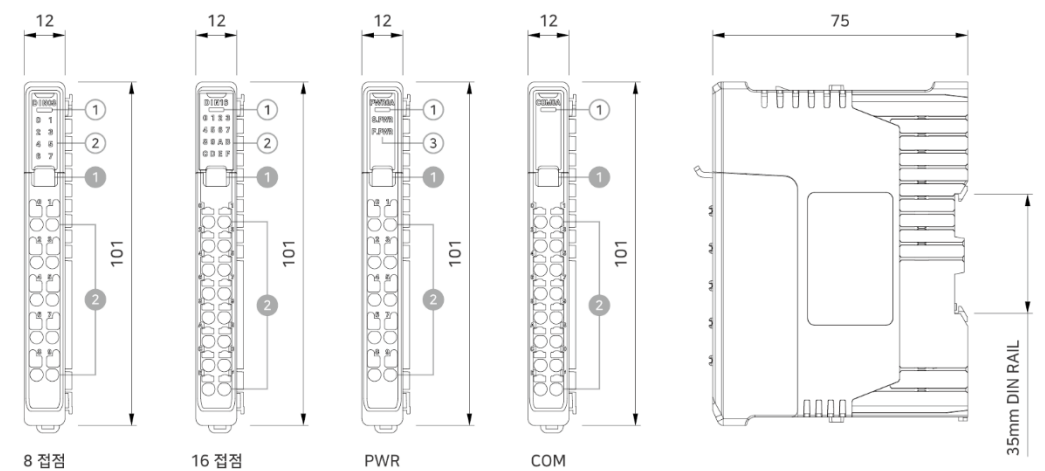

- ① Status LED
- ② Terminal Input Status LED
- ③ System/Field Power Status LED
- ① Detachment Hook
- ② Channel Terminal

MIO LoRa SERIES

Industrial Wireless Communication Device



MIO LoRa

FEATURES

Own Network and Protocols by LoRa Technology

No Extra Charges for Communication

Various I/O Supported in One LoRa EndNode

Digital IN/OUT, Relay Contacts, Analog Current/Voltage

Industrial Product Passed Multiple Tests, Safe and Powerful Functions

Pass Multiple Tests (Impact, Noise, Static, Temperature, etc.)

Convenient Method for Settings

Auto Switching Between LoRa Gateway and EndNode by MODE Button
Immediate Change of Frequency and SF Setting with Top-Side Switch

USER GUIDE

* Please Check Manual for Detailed Guide

- 01 Download the Settings of LoRa Gateway/EndNode with USB Cable in **[MX On LoRa Configurator]** Program
 - 02 Connect TOP and LoRa Gateway by **Serial Communication (RS-232C/422/485)**
 - 03 Add 'LoRa Gateway' to the Serial Port List in **[TOP Design Studio]** Program and Register Device ID in 'Communication Setup' for Each LoRa EndNode
- ! TOP can monitor and control a data of LoRa Gateway, and LoRa Gateway can transmit and receive a data with LoRa EndNode by LoRa Communication

INTERFACE

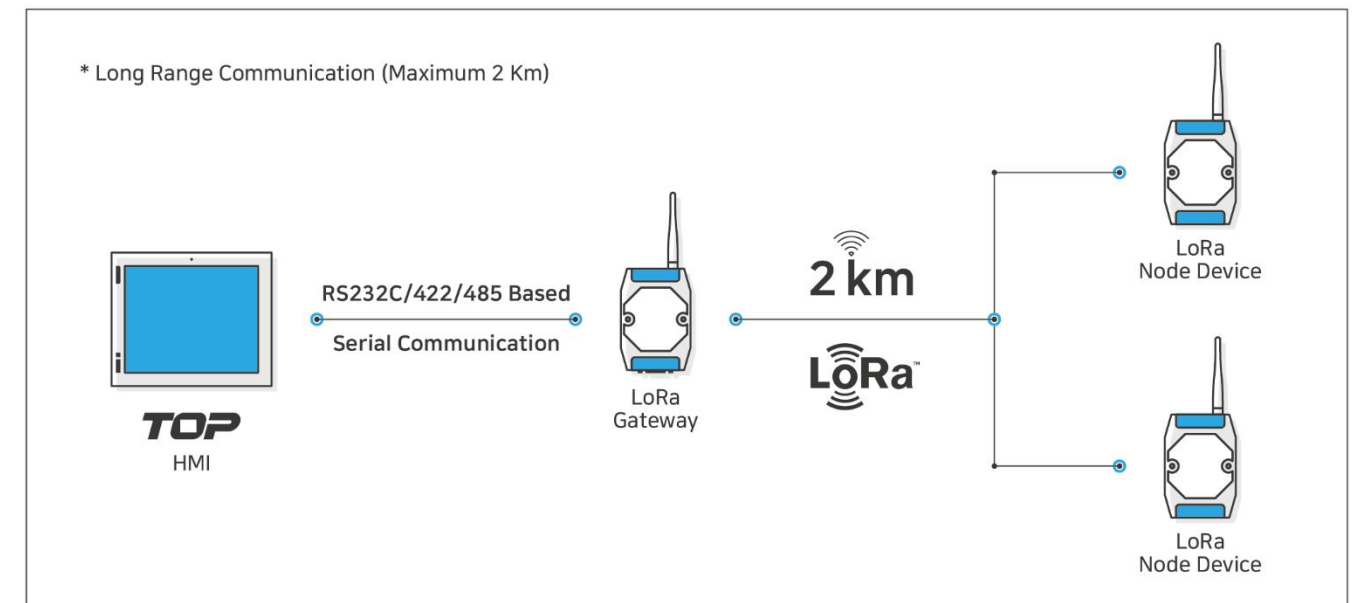

LoRa SPECIFICATIONS

GATEWAY

	Functional	MIO-LPG00
Power	Input Voltage	24Vdc(20 ~ 28Vdc)
	Power Dissipation	3W
	Voltage Sag	24Vdc, Within 10ms
	Insulation Resistance	500Vdc, 10MΩ
LoRa RF	RF Frequency	TX: 922.1 ~ 923.1 MHz, RX: 923.3 MHz
	Output Power	Max. 25mW(+14dBm, With Antenna)
	Communication Distance	Within 2Km
	Antenna	1T1R Dipole, +3.2dBm
	Security Setting	AES-128
Interface	Serial Comm.	RS-232C, 485/422 Asynchronous Data Bit: 7/8 Bits, Stop Bit: 1/2 Bits, Parity Bit: None/Odd/Even, Baud Rate: 2400 ~ 115.2kbps Connector: DSUB 9Pin x 1
	USB	Connector: USB Mini - B x 1
Other	Status LED	4 LEDs(Power, LoRa, Serial TX, RX) Built in
	Frequency Selection	Rotary Switch, Select 1 Out of 6 Channels
	SF Selection	Rotary Switch, Select 7 Out of 12 Setting
	Reset Button	Support
	Mode Button	Support
Environment	Operation Temperature(°C)	-10 ~ +50
	Storage Temperature(°C)	-20 ~ +60
	Operation Humidity(%RH)	0 ~ 90(No Dew)
	Atmosphere	No Corrosive Gas
	Vibration Endurance	Amplitude: 10sF < 25Hz(2G) X, Y, Z each Direction(for 30 Minutes)
	Noise Immunity	1000Vp-p(Pulse Width 1μs)
	Static Electricity Discharge	Connective Discharge from EN61000-4-2: ±4kV
	Shock Endurance	10G X, Y, Z each Direction(for 3 Times)
	Ground Connection	Class 3(100Ω Under)
	Protection Classification	IP20
Structure	Certification	KC
	External Dimension(mm)	72 x 305 x 44.6(*With Antenna)
	Weight(kg)	0.14
	Cooling System	Natural Air Circulation
	Case Material	ABS(Resistance to Flame)

LoRa SPECIFICATIONS

ENDNODE

	Functional	MIO-LPE00	
Power	Input Voltage	24Vdc(20 ~ 28Vdc)	
	Power Dissipation	3W	
	Voltage Sag	24Vdc, Within 10ms	
	Insulation Resistance	500Vdc, 10MΩ	
LoRa RF	RF Frequency	TX: 922.1 ~ 923.1 MHz, RX: 923.3 MHz	
	Output Power	Max. 25mW(+14dBm, With Antenna)	
	Communication Distance	Within 2Km	
	Antenna	1T1R Dipole, +3.2dBm	
	Security Setting	AES-128	
	Serial Comm.	-	
I/O Interface	USB	Connector: USB Mini - B x 1	
	Analog Current Input	Connector	3.5mm TB
		Assigned Channel	2 Channel
		Input Range	4 ~ 20 mA
	Resolution and Accuracy	16-bit, ±0.1%@25°C or better	
Analog Voltage Input	Connector	3.5mm TB	
	Assigned Channel	2 Channel	
	Input Range	0 ~ 5Vdc	
	Resolution and Accuracy	16-bit, ±0.1%@25°C or better	
Digital Input	Connector	3.5mm TB	
	Type	3 Channel Source or Sink	
	Output Current in On State	Max. 4mA/Channel @24Vdc	
Digital Output	Connector	3.5mm TB	
	Type	2 Channel Sink	
	Output Current in On State	Max. 0.5A/Channel @24Vdc	
Relay Output	Connector	3.5mm TB	
	Type	2 Channel Relay	
	Output Current in On State	1A/30Vdc, 0.3A/125Vac	
Other	Status LED	9 LEDs(Power, LoRa, Each I/O: 7LEDs) Built in	
	Frequency Selection	Rotary Switch, Select 1 Out of 6 Channels	
	SF Selection	Rotary Switch, Select 7 Out of 12 Setting	
	Reset Button	Support	
	Mode Button	Support	
Environment	Operation Temperature(°C)	-10 ~ +50	
	Storage Temperature(°C)	-20 ~ +60	
	Operation Humidity(%RH)	0 ~ 90(No Dew)	
	Atmosphere	No Corrosive Gas	
	Vibration Endurance	Amplitude: 10sF < 25Hz(2G) X, Y, Z each Direction(for 30 Minutes)	
	Noise Immunity	1000Vp-p(Pulse Width 1μs)	
	Static Electricity Discharge	Connective Discharge from EN61000-4-2: ±4kV	
	Shock Endurance	10G X, Y, Z each Direction(for 3 Times)	
	Ground Connection	Class 3(100Ω Under)	
	Protection Classification	IP20	
Structure	Certification	KC	
	External Dimension(mm)	72 x 300 x 44.6(*With Antenna)	
	Weight(kg)	0.14	
	Cooling System	Natural Air Circulation	
	Case Material	ABS(Resistance to Flame)	

DRAWING

MIO-LPG00 Gateway

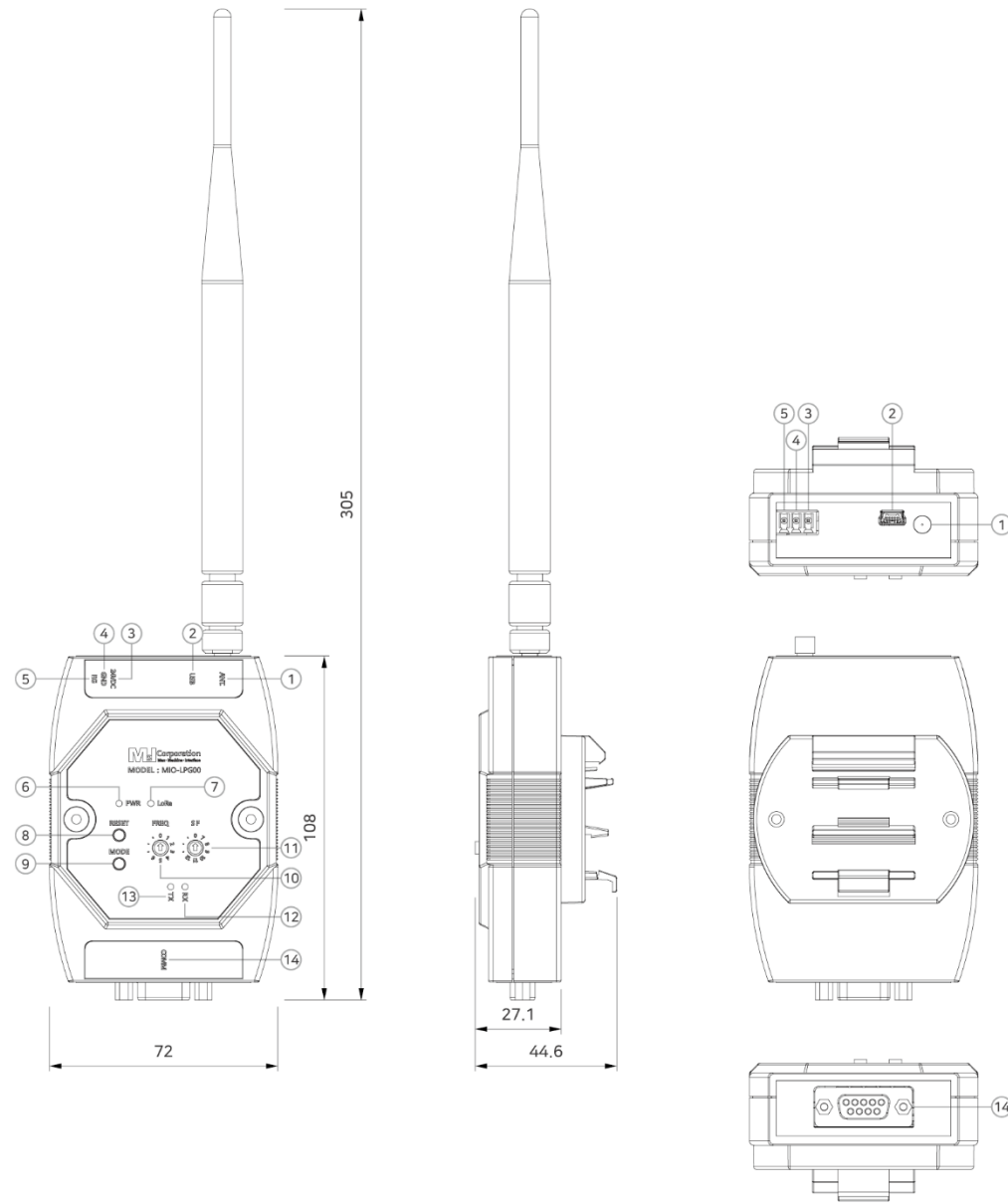

- ① LoRa Antena Joint
- ② USB Setting Connector
- ③ System Power Input(DC24V)
- ④ System Power GND
- ⑤ F.G
- ⑥ System Power Indicator
- ⑦ LoRa Communication Indicator
- ⑧ System RESET Switch
- ⑨ MODE Switch
- ⑩ Frequency Channel Switch [0 ~ 6]
- ⑪ SF Setting Switch [0], [7 ~ 12]
- ⑫ Communication Receive Indicator COMM
- ⑬ Communication Transmit Indicator COMM
- ⑭ Serial Communication Connector

DRAWING

MIO-LPE00 EndNode

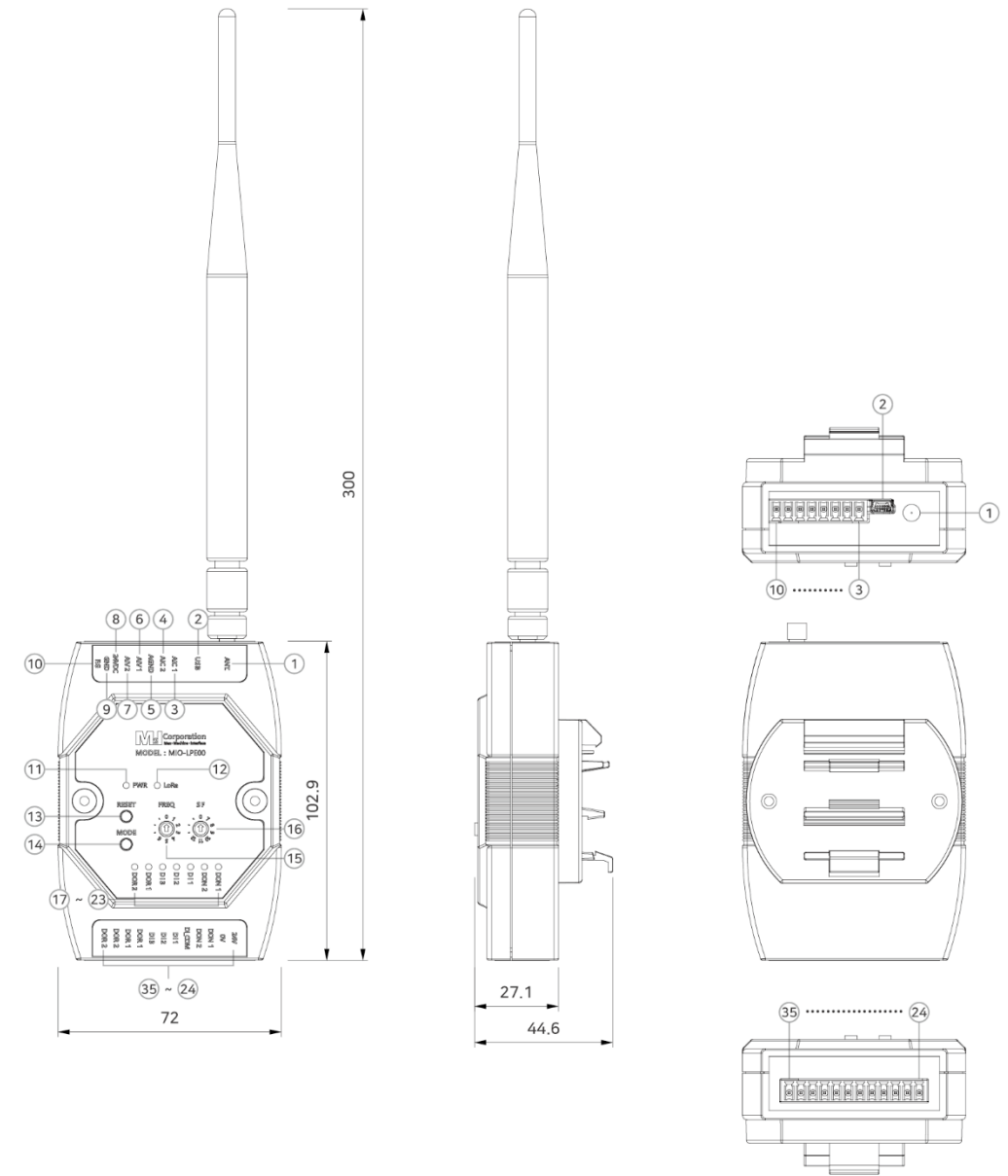

- ① LoRa Antena Joint
- ② USB Setting Connector
- ③ Analog Current Input Terminal for Channel 1
- ④ Analog Current Input Terminal for Channel 2
- ⑤ AIC 1, 2/AIV 1, 2 Common Terminal
* Field Power(0V) Connection Terminal
** Use when it is connected as Source Type
- ⑥ Analog Voltage Input Terminal for Channel 1
- ⑦ Analog Voltage Input Terminal for Channel 2
- ⑧ System Power Input(DC24V)
- ⑨ System Power GND
- ⑩ F.G
- ⑪ System Power Indicator
- ⑫ LoRa Communication Indicator
- ⑬ System RESET Switch
- ⑭ MODE Switch
- ⑮ Frequency Channel Switch [0 ~ 6]
- ⑯ SF Setting Switch [0], [7 ~ 12]
- ⑰ ~ ⑳ Operation Status LED
- ㉑ ~ ㉓ I/O Terminal

MGW SERIES

IoT Gateway Connecting Industrial Equipment



FEATURES

Communication Protocol Converter (Multiple Communication Driver)

Same Dedicated Communication Protocol as HMI (Address-Based PLC) Communication Library

Standard DIN Rail / VESA Hall Supported

Easy Installation by Standard DIN Rail
Simple Assembly with Monitors by Standard VESA Bracket (* Option)

Operating on TOP Design Studio Software

Easy Design with Same Software for MX On's HMI/SCADA Users

Ethernet 2 Ports / Serial 2 Ports

Ethernet 2 Channels with Independent IP
COM1/2 DSUB 9-Pin (RS-232C, RS-422/485)

HDMI Output

Connection with Various Monitors Through HDMI and DP
Compatible with MX On's Exclusive Touch Monitor (MDP)

MGW CONNECTION METHODS

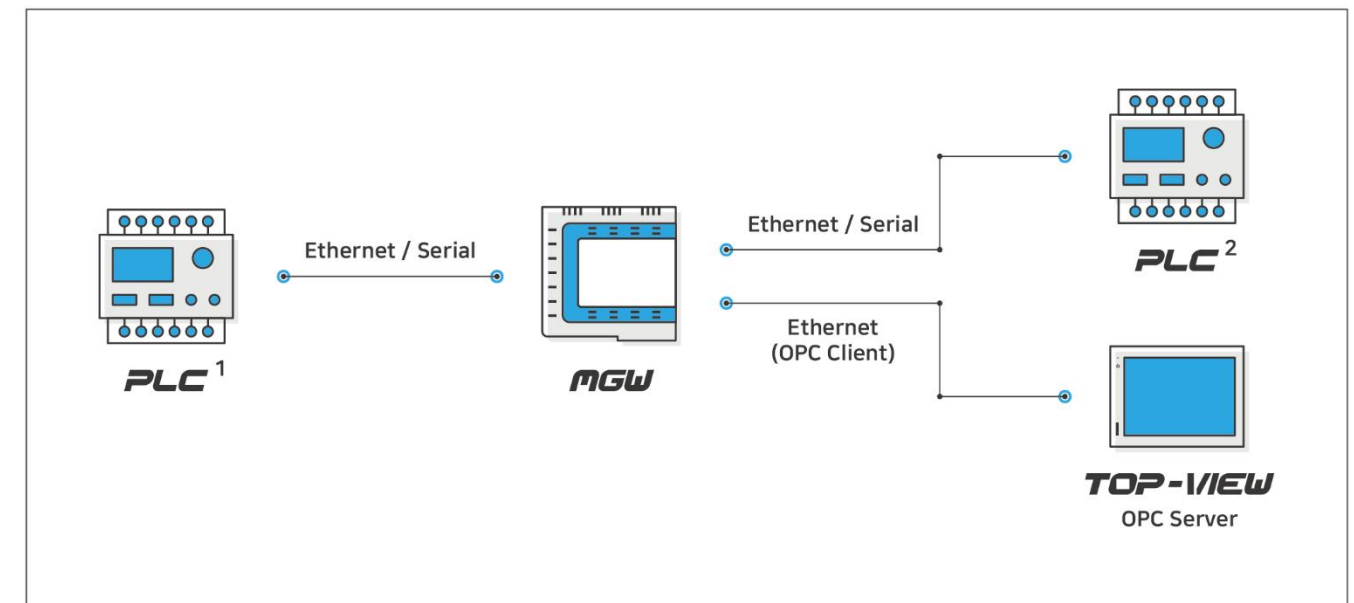

MGW SPECIFICATIONS

Functional	MGW-BH1000D
Serial COM1	RS-232C, RS-422/485 Asynchronous +5Vdc PWR Data bit: 7/8 bits, Stop bit: 1/2 bits, Parity bit: None/Odd/Even Baud rate: 2400~115.2kbps Connector: DSUB 9pin x 1
Serial COM2	RS-232C, RS-422/485 Asynchronous Data bit: 7/8 bits, Stop bit: 1/2 bits, Parity bit: None/Odd/Even Baud rate: 2400~115.2kbps Connector: DSUB 9pin x 1
Ethernet	IEEE802.3i/IEEE802.3u, 10BASE-T/100BASE-TX Connector: RJ-45 x 2
USB Host	USB 2.0 Compatible, Output 5Vdc/0.5A Support: USB Storage, USB Barcode Scanner(Standard Keyboard Protocol) Connector: USB Type A x 2
USB OTG	USB 2.0 Compatible, Output 5Vdc/0.5A, Max 3m Support: USB Storage, USB Barcode Scanner(Standard Keyboard Protocol) Connector: USB Mini-B x 1
SD Card	SD Card Slot x 1, SDHC(MAX 32GB)
HDMI Output	HDMI v1.4, HDMI Output, Max. Resolution: 1280x720 at 60Hz Connector: HDMI x 1
Printer	Roll Printer(EPSON protocol)
Screen Memory	128MB
Backup Memory	512KB: System buffer(10K Word), Including Alarm/Logging/Recipe
Backup Period	Permanent
Real Time Clock	Built in
Status LED	3 LEDs(Power, Operation, SD Card) Built in
Input Voltage	20~28Vdc
Power Consumption	10W
Voltage Sag	24Vdc, Within 10ms
Insulation Resistance	500Vdc, 10MΩ
Operation Temperature(°C)	-10 ~ +50
Storage Temperature(°C)	-20 ~ +60
Operation Humidity(%RH)	0 ~ 90(No dew)
Atmosphere	No corrosive gas
Vibration Endurance	Amplitude: 10≤F<25Hz(2G) X,Y,Z each direction(for 30 minutes)
Noise Immunity	1000Vp-p(Pulse width 1μs)
Electrostatic Discharge	Connective discharge from EN61000-4-2: ±4kV
Shock Endurance	10G X,Y,Z each direction(for 3 times)
Ground Connection	Class 3(100Ω or less)
Protection Classification	IP20
Certification	KC, CE, UL/cUL
External Dimension(mm)	128.9x131.2x29.2
Weight(kg)	0.23
Installation Method	Standard DIN Rail(35mm), VESA
Cooling System	Natural air circulation
Case Material	Plastic

DRAWING

MGW-BH1000D

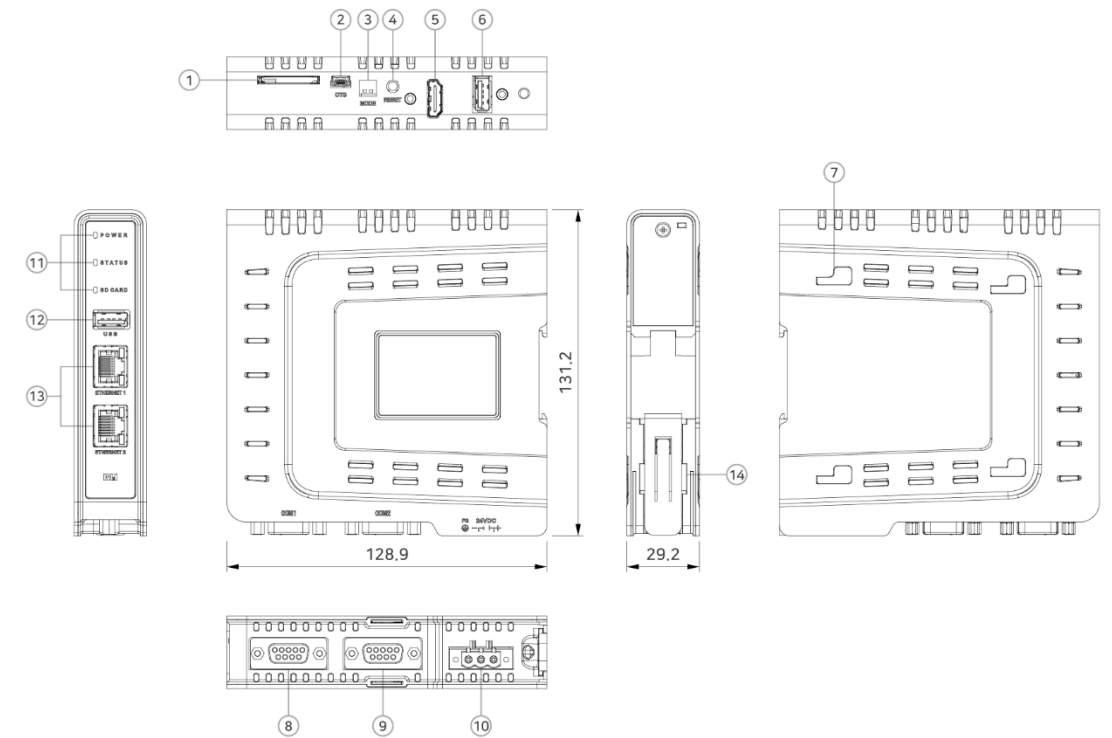

- ① SD Card Socket
- ④ Reset Switch
- ⑦ Vesa Bracket
- ⑩ Power Input
- ⑬ Ethernet Port
- ② USB OTG
- ⑤ HDMI
- ⑧ Serial COM1
- ⑪ Status LED
- ⑭ DIN Rail
- ③ Mode Switch
- ⑥ USB Host #1
- ⑨ Serial COM2
- ⑫ USB Host #2

VESA Braket(*Option)

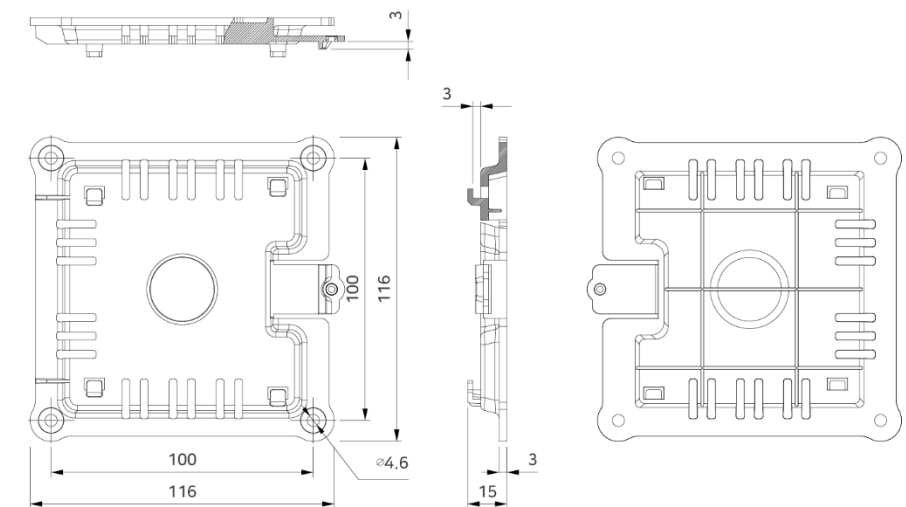

GLOBAL BUSINESS NETWORK



More than 20 Overseas Partners

China, the United States, Vietnam, Japan, South Africa, Turkiye, Singapore, Russia, Greece, France, Jordan, Honduras, Nigeria, Indonesia, India, Israel, Iran, Thailand, Malaysia, and more.

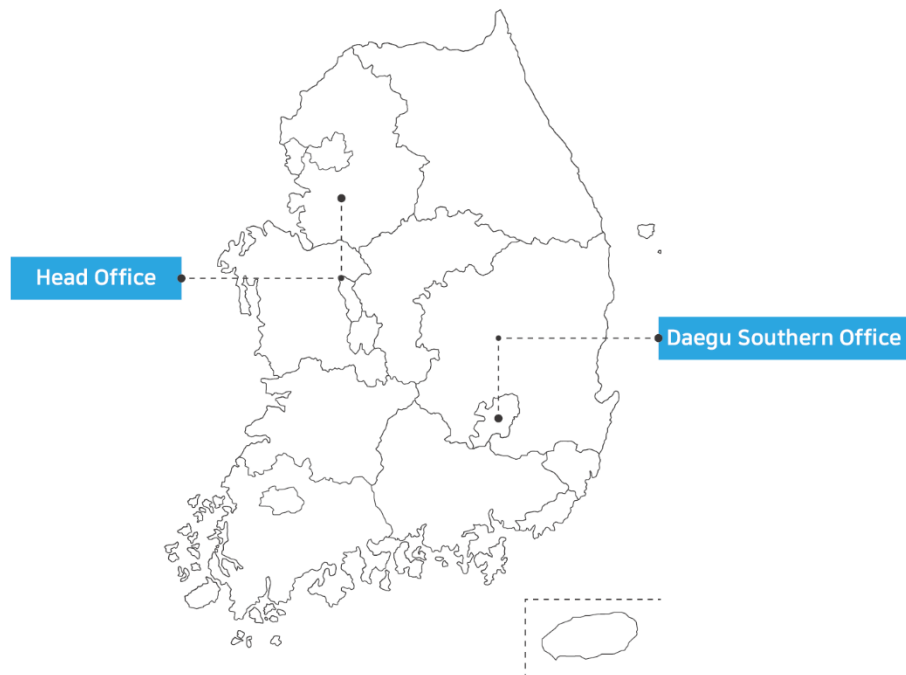

More than 40 Domestic Partners

Seoul, Gyeonggi, Daejeon, Daegu, Gwangju, Ulsan, Changwon, Busan, and more.

MX On Official YouTube Channel

Access a Wide Range of Educational Content and the Latest Updates from MX On, Faster Than Anywhere Else



KakaoTalk Technical Support

Quickly and Efficiently Resolve Technical Issues by Sending Real-Time Photos and Videos, Even in Noisy Industrial Environments



On-Site Inspection Service (B/S, Field Visit)

From Checking Aging Products to Consulting for New Replacements, Experience It All Directly at Your Site Now



Commitment to Our Customers

Dialogue with Customers – Putting Customers First and Creating Value Together
 Sustainable Growth – Achieving Reliability and Productivity Through Continuous R&D
 Embracing New Changes – A Total Smart Factory Solution Platform Company Based on AX·DX